



**BUILT-IN  
APPLIANCES**  
2009 Collection

**BEKO**



## FRIDGES

BC73F / BC50F

Aperture cut-out: H1776-1789 \* W560 \* D550

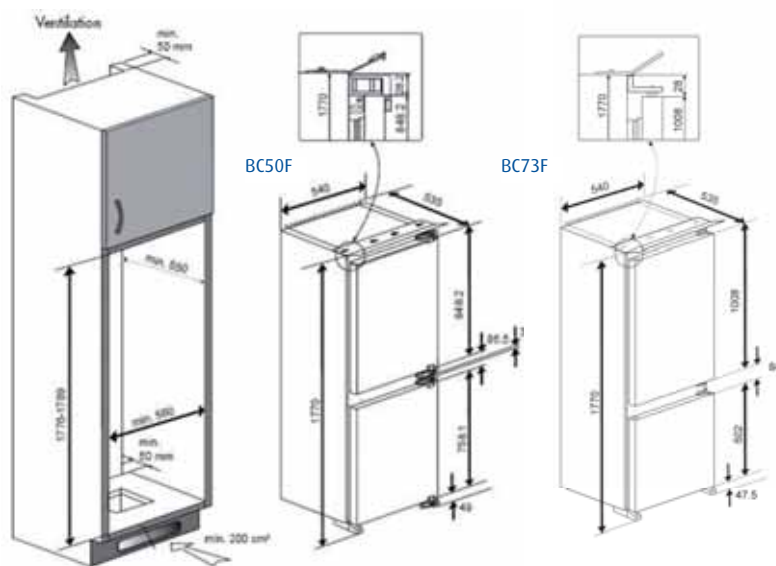

BL20 / BZ30

Aperture cut-out: H820-870 \* W600 \* D550

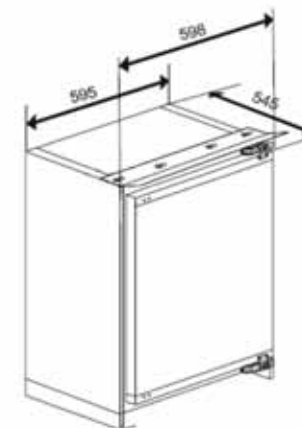

## HOB'S

HIC64102, HIZ64120 / HIZE64101, HIC64402T

Aperture cut-out: W560 \* D490

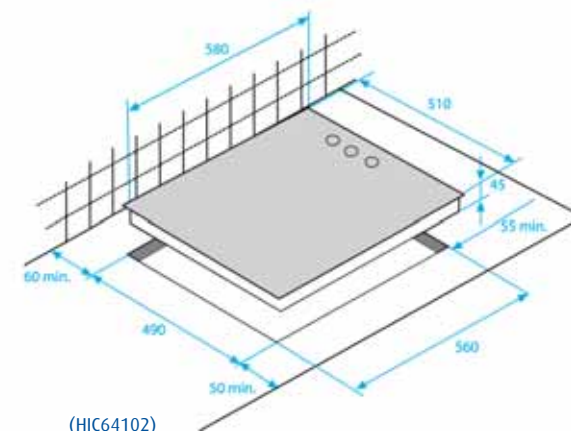

(HIC64102)

**Welcome to the world of Beko Built-In appliances where functionality and simplicity blend harmoniously with elegance and style.**

The kitchen is increasingly the focal point of the home where we spend more and more time. It is where families get together and friends meet and chat. Beko Built-In appliances allow you to create affordable and contemporary kitchens designed to withstand the demands of a busy family life with useful features suited to your individual needs.

Using the latest technology and state-of-the-art engineering techniques, the Beko Built-In range offers a wide range of quality, energy efficient products that allow you to create an individual kitchen perfectly matched to the style of your choice.

All appliances in the range are 'A' energy class rated\*. The new cooking range features stainless steel handles (except white models), high quality hinges and robust doors which carry 20% more weight than current standards impose. They also now have a massive oven capacity (65 or 67 litres) and include a recessed grill element and hinges for easy door removal.

\* Excludes washer/dryer

# BEKO

## DISHWASHERS

DW450

Aperture cut-out: H820-920 \* W450 \* D570

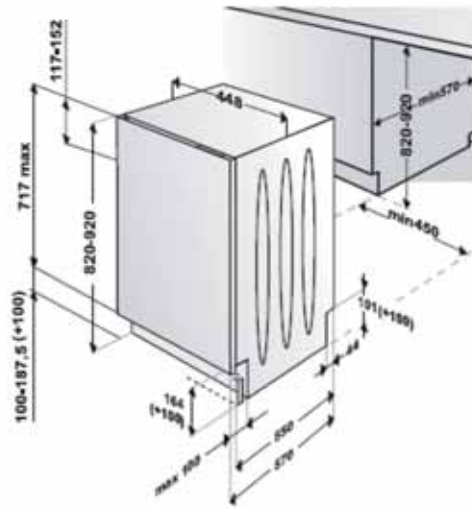

DW600

Aperture cut-out: H820-920 \* W600 \* D570

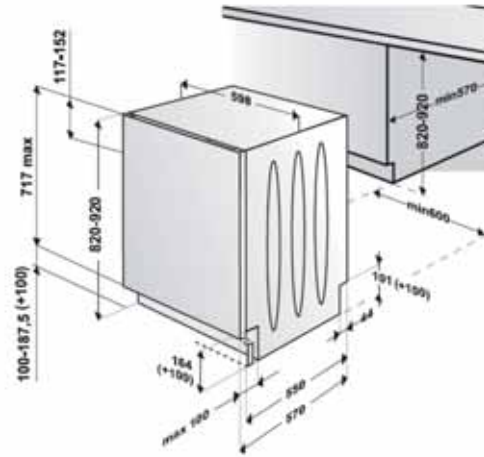

OTF12300

Aperture cut-out: H720 \* W560-570 \* D550

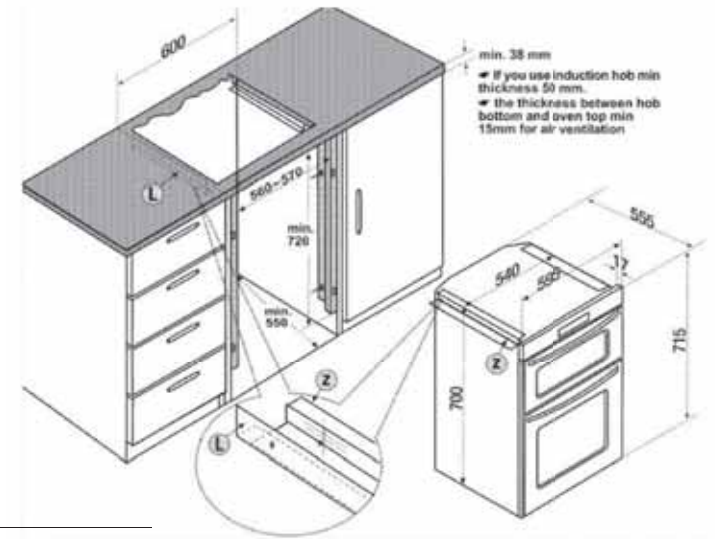

ODF22300/ODF21300

Aperture cut-out: H880 \* W560 \* D550

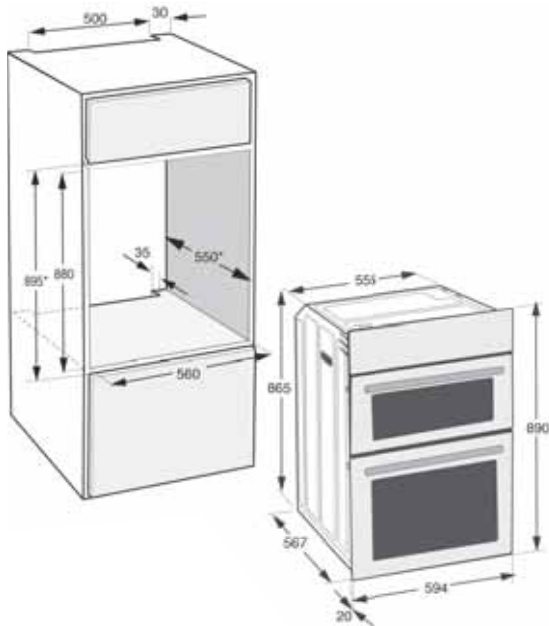

## OVENS (All ovens have plastic lined carry handles for ease of installation)

OIF22300 XL/XR, OIF22300/OIF21300,  
OIF21100/OIF22100, OIM22300, OIC21000  
Aperture cut-out: H590 \* W560 \* D550

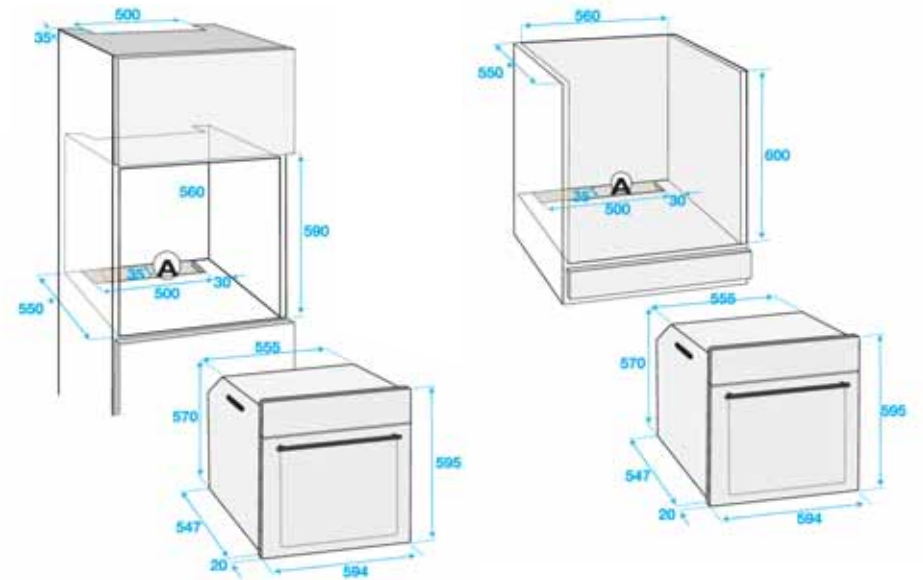

# Ovens



## OIF22300 XL/XR

**Fan Oven with Left or Right Hand Side Opening Door & LED Programmer**

### Main Features

- Massive oven capacity 65 litres
- 'A' energy rating
- Easy access side opening door
- Telescopic runner system
- Programmable oven with large display LED timer
- Recessed grill element
- Easy grip silver coloured matching control knobs
- 'Easy Clean' double glazed oven door with full glass inner door
- Maximum oven visibility – large viewing window and interior light
- Diamond quality easy clean enamel oven interior

### Technical Information

- Fully variable grill function
- 5 function settings
  - Fan heating
  - Variable grill
  - Fan and grill
  - Defrost
  - Light
- One wire shelf with stop position system
- Full width enamel cooking tray with internal grill rack

**Stainless Steel - OIF22300XL (Left hand hinge)**

**Stainless Steel - OIF22300XR (Right hand hinge)**



## OIF22300 / OIF21300

**60cm Fan Oven with LED Programmer**

### Main Features

- Massive oven capacity 65 litres
- 'A' energy rating
- Programmable oven with large display LED timer
- Recessed grill element
- Easy grip silver coloured matching control knobs
- 'Easy clean' double glazed oven door with full glass inner door
- Maximum oven visibility – large viewing window and interior light
- Diamond Quality easy clean enamel oven interior

### Technical Information

- Fully variable grill function
- 5 function settings
  - Fan heating
  - Variable grill
  - Fan and grill
  - Defrost
  - Light
- Two wire shelves
- Full width enamel cooking tray with internal grill rack

**White - OIF21300W**

**Stainless Steel - OIF22300X**

**Black - OIF21300B**



## OIF21100 / OIF22100

**60cm Fan Oven with Minute Minder**

### Main Features

- Massive oven capacity 65 litres
- 'A' energy rating
- 100 min auto-cut off mechanical minute minder
- Recessed grill element
- 'Easy clean' double glazed oven door with full glass inner door
- Maximum oven visibility – large viewing window and interior light
- Diamond quality easy clean enamel oven interior

### Technical Information

- Fully variable grill function
- 5 function settings
  - Fan heating
  - Variable grill
  - Fan and grill
  - Defrost
  - Light
- Full metal control panel
- Easy grip control knobs
- Two wire shelves
- Full width enamel cooking tray with internal grill rack

**White - OIF21100W**

**Stainless Steel - OIF22100X**



## OIC21000

**Traditional 60cm Conventional Oven**

### Main Features

- Massive oven capacity 67 litres
- 'A' energy rating
- Recessed grill element
- 'Easy clean' double glazed oven door with full glass inner door
- Maximum oven visibility – large viewing window and interior light
- Diamond quality easy clean enamel oven interior

### Technical Information

- Fully variable grill function
- 4 function settings
  - Top and bottom heat
  - Bottom heater
  - Grill
  - Low grill
- Full metal control panel
- Easy grip control knobs
- Two wire shelves
- Full width enamel cooking tray with internal grill rack

**White - OIC21000W**

# Ovens



## OIM22300

### Multi Function Oven with LED Programmer

#### Main Features

- Massive oven capacity 65 litres
- 'A' energy rating
- Programmable oven with large display LED timer
- Recessed grill element
- Easy grip silver coloured matching control knobs
- 'Easy clean' double glazed oven door with full glass inner door
- Maximum oven visibility – large viewing window and interior light
- Diamond quality easy clean enamel oven interior

#### Technical Information

- Fully variable grill function
- 8 function settings
  - Fan/Defrost
  - Static
  - Static and fan
  - Fan heating
  - Bottom heater
  - Low grill fan
  - Grill
  - 3D Cooking
- Two wire shelves
- Full width enamel cooking tray with internal grill rack

**Stainless steel - OIM22300X**



## OTF12300

### 72cm Built Under/In Column Double Oven

#### Main Features

- Large fan main oven and top conventional oven with fully variable grill
- 'AB' energy rating
- Large display programmable LED timer (main oven)
- Recessed grill element
- Easy grip silver colour control knobs
- 'Easy clean' double glazed glass door with large viewing window
- Diamond quality easy clean enamel oven interior

#### Technical Information

- Full metal control panel
- Main fan oven – 3 functions
  - Fan heating
  - Defrost
  - Light
- Top oven - 4 functions
  - Top and bottom heat
  - Bottom heater
  - Grill
  - Low grill
- Three wire shelves with stop position system
- Full width enamel cooking tray with internal grill rack

**Stainless steel - OTF12300X**

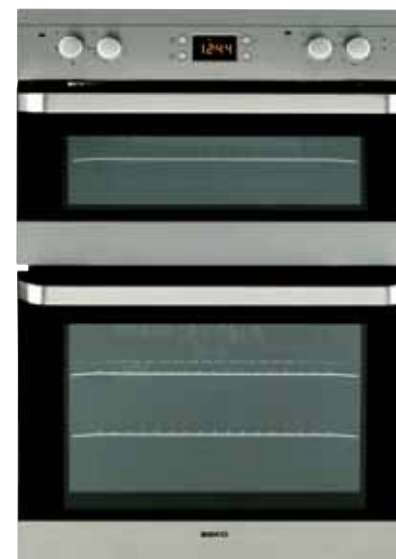

## ODF22300 / ODF21300

### 90cm Built In Double Oven

#### Main Features

- Fan main oven, top conventional oven with integral grill
- 'AA' energy rating
- Large capacity main oven compartment (65 litres)
- Programmable oven with large display LED timer
- Recessed grill element
- 'Easy clean' double glazed glass door with large viewing window
- Diamond quality easy clean enamel oven interior

#### Technical Information

- Main fan oven – 3 functions
  - Top oven – 4 functions
  - Fan heating
  - Top and bottom heat
  - Defrost
  - Bottom heater
  - Light
  - Grill
  - Low grill
- Easy grip control knobs
- Three wire shelves with stop position system
- Standard baking tray with internal grill rack and handle

**White - ODF21300W**

**Black - ODF21300B**

**Stainless Steel - ODF22300X**

# Hobs

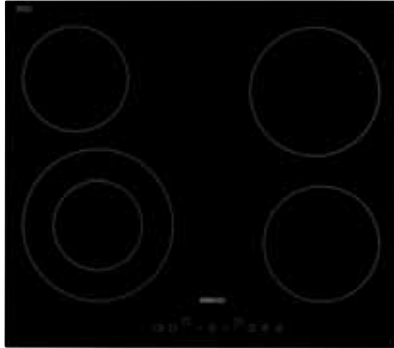

## HIC64402T

### 60cm Touch Control Ceramic Hob

- Frameless ceramic hob
- Easy to clean hob surface
- Dual zone provides cooking flexibility
- 4 Rapidlite heating zones
- 1-9 adjustable power levels
- Timer
- Child lock – for safety
- Auto shut off – If left on for a long period of time
- 4 residual heat indicators



## HIZG64120

### 60 cm Gas Hob with Auto Ignition

- 4 burner gas hob with 3 different sizes
- Auto ignition easy grip knobs
- Gloss enamel pan supports
- Easy to clean one piece hob plate
- FSD option available
- Suitable for LPG conversion

**White - HIZG64120W**

**White with FSD - HIZG64120SW**

**Stainless Steel - HIZG64120X**

**Stainless Steel with FSD -**

**HIZG64120SX**

**Black - HIZG64120B**

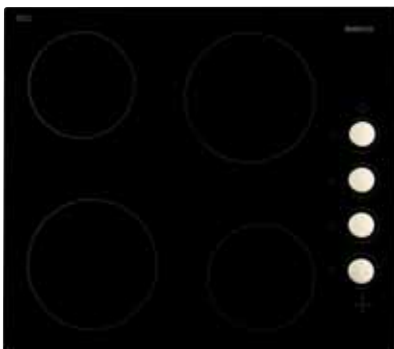

## HIC64102

### 60cm Frameless Ceramic Hob

- Easy to clean hob surface
- Easy grip side control knobs
- 4 Rapidlite heating zones
- 1-6 adjustable power levels
- 4 residual heat indicators



## HIZE64101

### 60 cm Sealed Plate Electric Hob

- Easy to clean one piece hob plate
- 4 sealed plates with 2 rapid zones
- On/off power light
- Residual heat indicator

**White - HIZE64101W**

**Stainless Steel - HIZE64101X**

## Dishwashers



### DW450

#### Slimline Dishwasher

##### Main Features

- 'AAA' rated
- 10 place settings
- Electronic programme chooser
- 5 wash programmes
  - Pre-wash
  - Economy
  - Intensive 70°C
  - Rapid
  - Quick and clean
- 4 wash temperatures

##### Technical Information

- Height adjustable upper basket
- Upper basket with folding racks
- Folding plate supports in lower basket
- Salt and rinse aid indicator lights
- Hot air drying system
- Removable cutlery basket



### DW600

#### Full Size Dishwasher

##### Main Features

- 'AAB' rated
- 12 place settings
- Electronic programme chooser
- 5 wash programmes
  - Pre-wash
  - Economy
  - Intensive 70°C
  - Rapid
  - Quick and clean
- 4 wash temperatures

##### Technical Information

- Height adjustable upper basket
- Upper basket with folding racks
- Folding plate supports in lower basket
- Salt and rinse aid indicator lights
- Removable cutlery basket

## Washer/Dryer



### BWD6421

#### Fully Integrated Washer Dryer

##### Main Features

- 'BAC' rated
- 1200rpm
- 6kg washing and 4kg drying capacity
- LCD display showing time remaining
- Time delay up to 24 hours
- Spin speed reduction button
- 15 wash programmes including;
  - Quick wash
  - Intensive
  - Cold wash
  - Prewash
  - Wool
  - Delicates
- Safety lock during wash cycles

##### Technical information

- Large porthole door with wide opening angle
- 4 adjustable feet
- Reversible door

# Fridge Freezers



## BL20

### 'A' Rated Fully Integrated Larder Fridge

#### Main Features

- 'A' energy rating
- Reversible door
- Heavy duty self closing metal hinges to ensure door is not left ajar
- Auto defrost

#### Technical Information

- Total capacity 4.6 cu. ft. (gross)
- 2 adjustable glass shelves
- 1 full width bottle rack
- 1 full width commodity rack
- Adjustable feet for levelling



## BZ30

### 'A' Rated Fully Integrated Freezer

#### Main Features

- 'A' energy rating
- Reversible door
- Heavy duty self closing metal hinges to ensure door is not left ajar
- Indicator lights:
  - Green: Mains on
  - Red: High temperature warning
  - Amber: Fast freeze activated
- Adjustable feet for levelling

#### Technical Information

- Total capacity 3.4 cu. ft. (gross)
- Manual defrost
- Fast freeze switch
- 4 separate compartments:
  - Drop down flap
  - 2 drawers both with transparent front
  - Concealed compartment below bottom drawer



## BC50F

### 'A' Rated Combi Frost Free Fridge Freezer

#### Main Features

- 'A' energy rating
- Total capacity 8.1 cu. ft. (gross)
- Reversible doors

#### Technical Information

##### Fridge

- 5.5 cu. ft. net capacity
- 3 adjustable glass shelves
- Chrome wire wine rack

##### Freezer

- 2.2 cu. ft. net capacity
- Four separate compartments
  - 3 full depth compartments, one with drop down flap
  - Half depth plastic drawer



## BC73F

### 'A' Rated Combi Frost Free Fridge Freezer

#### FROST FREE

#### Main Features

- 'A' energy rating
- Total capacity 9.7 cu. ft. (gross)
- Reversible doors

#### Technical Information

##### Fridge

- 6.7 cu. ft. net capacity
- 3 adjustable glass shelves
- Chrome wire wine rack

##### Freezer

- 1.7 cu. ft. net capacity
- 3 separate compartments
  - 2 full depth compartments, one with drop down flap
  - Half depth plastic drawer

# BEKO

[www.beko.co.uk](http://www.beko.co.uk)

Beko plc. Beko House, Caxton Way, Watford, Hertfordshire WD18 8UF

Tel - 0845 6004904 Fax - 0845 6004925

Beko plc continuously seek improvements in specification, design and production of products and thus alterations take place periodically. Whilst every effort is made to produce up-to-date literature, this brochure should not be regarded as an infallible guide to current specification, nor does it constitute an offer for the sale of any particular appliance.